

with Touch Panel

5.7" Passive Matrix Color LCD Module
KCG057QV1DC-G50

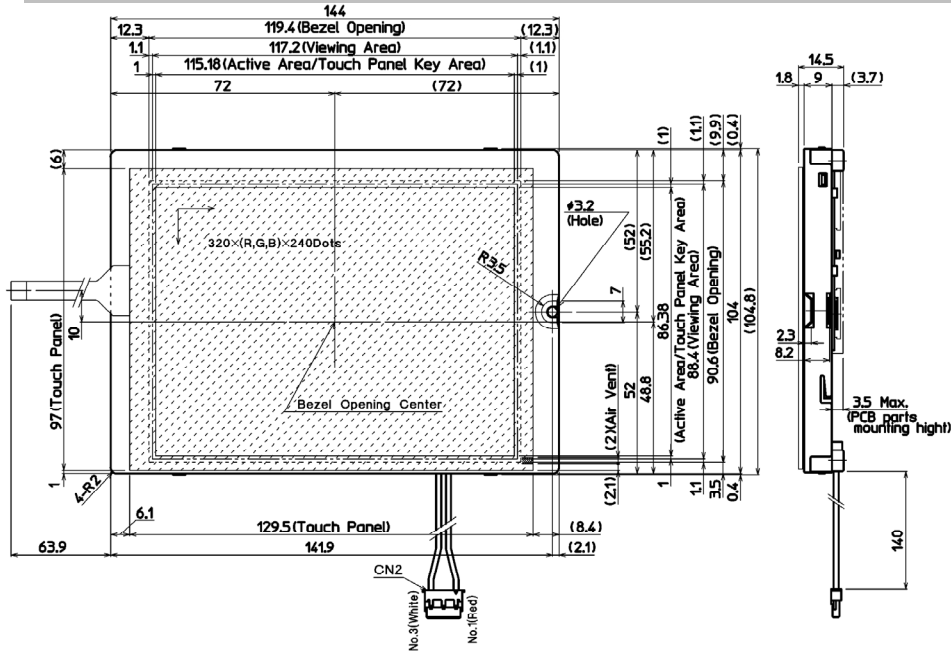

Features

- With Touch Panel
- Symmetrical Design (Horizontal)
- DC-DC Converter Included
- Long Life CFL 75,000 (h)
- High Brightness 280 (cd/m²)

Applications

- Display for Industrial Machine
- Measuring Instrument, Chart Recorder, Scale
- POS, ATM, Bank Terminal
- Musical Instrument, Sewing Machine
- Home-use FAX (L-mode)

Specification

ITEM	SPECIFICATION	UNIT
Dot Format	(320 × RGB) × 240	dot
Dot Pitch	0.12 × 0.36	mm
Outline Dimensions	144.0 × 104.8 × 14.5	mm
Mass	220	g
Contrast Ratio	55:1	—
Brightness	280	cd/m ²
Response Time	350	ms
Viewing Angle (V/H)	55/100	deg.
Power Consumption	133.7 (VDD=3.3V)	mW
	135.0 (VDD=5.0V) (LCD)	
	2.74 (Backlight)	W
Backlight	CFL (Single Tube)	—
Duty	1/240	—

ATTENTION : Specification subject to change without notice.
 Please check the latest version of the product specification.

KYOCERA CORPORATION
LCD Division

6 Takeda Tobadono-cho, Fushimi-ku, Kyoto 612-8501 Japan
 Phone: +81-75-604-3751 <http://www.kyocera.co.jp/lcd/>

- KYOCERA INDUSTRIAL CERAMICS CORPORATION (USA)
 Phone (Toll Free) : +1-800-826-0527 <http://www.kyocera.com/>
- KYOCERA FINECERAMICS GmbH (GERMANY)
 Phone : +49-711-939-3418 <http://www.kyocera.de/>
- KYOCERA FINECERAMICS S.A. (FRANCE)
 Phone : +33-1-45120239
- KYOCERA FINECERAMICS LTD. (UK)
 Phone : +44-1252-776000
- KYOCERA ASIA PACIFIC PTE. LTD. (SINGAPORE)
 Phone : +65-6271-0500
- KYOCERA ASIA PACIFIC PTE. LTD. TAIPEI BRANCH (TAIWAN)
 Phone : +886-2-2555-3609
- KYOCERA ASIA PACIFIC LTD. (HONG KONG)
 Phone : +852-2723-7183